

# Product data sheet

## Characteristics

# 2510FG2

Manual Starter, fractional horsepower, 16A, 2 poles, 1 HP at 277 VAC, toggle operated, no indicator, NEMA 1 enclosure



Product availability: Stock - Normally stocked in distribution facility

Price\*: 104.04 USD



### Main

Product or component type	Single Unit Manual Starter
Range of product	F
Thermal overload type	Melting alloy

### Complementary

Line Rated Current	16 A
Cable entry	0.5" and 0.75" knock-outs (top and bottom)
Maximum Horse Power Rating	1 Hp 115 V AC 1 Hp 277 V AC 0.75 Hp 115 V DC 0.75 Hp 230 V DC 2 Hp 230 V AC
[Ue] rated operational voltage	277 V AC 230 V DC
Poles description	2P
Control type	Toggle switch
Phase	1 phase
Local signalling	No indicator
Reset	Manual
Motor starter type	Non reversing
Electrical connection	Screw clamp terminals
AWG gauge	AWG 14...AWG 12 copper
Height	4.25 In (107.95 mm)
Width	2.44 In (61.98 mm)
Depth	2.75 In (69.85 mm)
Net weight	0.79 Lb(US) (0.36 kg)

## Environment

Product certifications	UL listed file E42243 CCN NLRV CSA LR25490 class 3211 05
NEMA degree of protection	NEMA 1 Plastic standard size

## Ordering and shipping details

Category	21101 - 2510,2511,2512 F
Discount Schedule	CP1
GTIN	00785901553953
Nbr. of units in pkg.	1
Package weight(Lbs)	12.64 Oz (358.338 g)
Returnability	Yes
Country of origin	MX

## Packing Units

Unit Type of Package 1	PCE
Package 1 Height	2.60 In (6.604 cm)
Package 1 width	3.00 In (7.62 cm)
Package 1 Length	4.70 In (11.938 cm)
Unit Type of Package 2	CAR
Number of Units in Package 2	14
Package 2 Weight	11.68 Lb(US) (5.298 kg)
Package 2 Height	8.90 In (22.606 cm)
Package 2 width	8.30 In (21.082 cm)
Package 2 Length	14.50 In (36.83 cm)
Unit Type of Package 3	PAL
Number of Units in Package 3	624
Package 3 Weight	493.00 Lb(US) (223.621 kg)
Package 3 Height	40.00 In (101.6 cm)
Package 3 width	40.00 In (101.6 cm)
Package 3 Length	48.00 In (121.92 cm)

## Offer Sustainability

California proposition 65	WARNING: This product can expose you to chemicals including: Lead and lead compounds, which is known to the State of California to cause cancer and birth defects or other reproductive harm. For more information go to <a href="http://www.P65Warnings.ca.gov">www.P65Warnings.ca.gov</a>
REACH Regulation	<a href="#">REACH Declaration</a>
REACH free of SVHC	Yes
EU RoHS Directive	Not compliant
China RoHS Regulation	<a href="#">China RoHS Declaration</a>
PVC free	Yes

## Contractual warranty

Warranty	18 months
----------	-----------

Approximate Dimensions

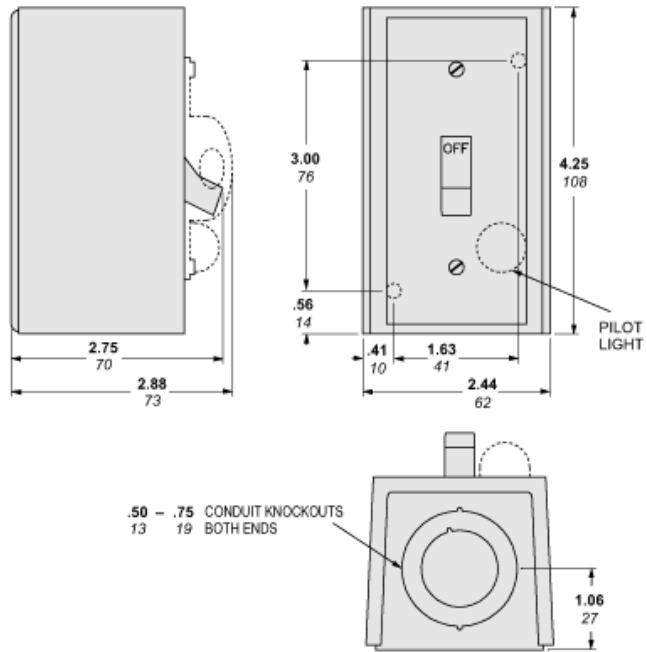

Product Life Status : Commercialised